

GEZE TS 550 Floor Spring



Installation Instructions

WARNING: DOOR CLOSERS WITH A POWER RATING LOWER THAN 3 OR WITH MECHANICAL HOLD OPEN DEVICES ARE NOT SUITABLE FOR USE WITH FIRE DOORS.

Components Checklist:

- | | |
|---------------------------------------|--------------------------|
| 1 x Closer body | 1 x clamp plate (fitted) |
| 1 x Cement box (fitted) | 1 x spindle (fitted) |
| 4 x Height adjustment screws (fitted) | 1 x reinforcement plate |
| 1 x spindle bolt (fitted) | |
| 3 x clamp screws (fitted) | |

Tools Required For Installation:

- Flat head screwdriver
- 10mm Spanner
- 5mm Allen key (supplied)

User Information for Door Closers

This information must be observed. Non compliance will absolve the manufacture from any liability. The door closer must only be used in accordance with its intended use; i.e. closing of side hung doors following manual opening.

Incorrect use may cause injury

- Obstruction of closing process (e.g. dragging doors, sticking weather strips/sealing rubbers, rough-running locks)
- Incorrect installation and adjustment (e.g. slamming doors)
- Danger of finger trap between frame and door leaf.
- Wrong size door closer.
- Closer used for other purpose than to close side hung doors.

Maintenance:

NOTE:

- Maintenance to be carried out by a specialist only.
- Check assembly for tolerance and undue wear.
- Tighten any screws that may have become loose.

At least once a year:

- Grease moveable parts.
- Check operation of doors and adjust if necessary.
- For door closers subject to release by Electro Mechanical and Electro Hydraulic means ensure that local regulation are adhered to.

Installation and adjustment by specialist only

Where necessary, an additional doorstop or buffer must be fitted to limit the maximum opening of the door. This is of particular relevance for slide rail closers where the opening angle may be limited by frame. For further explanations see catalogue preface and product information.

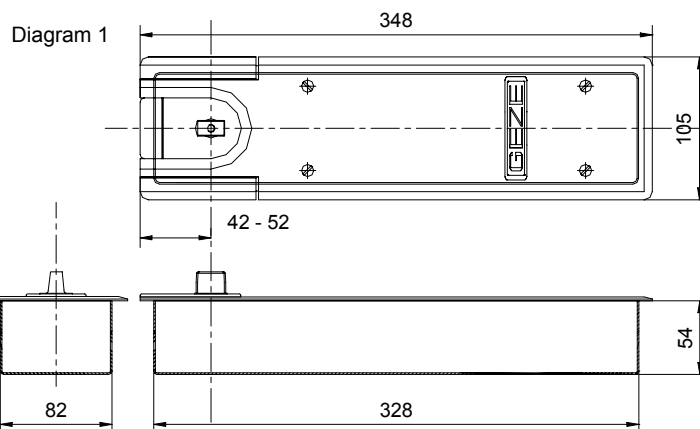

Door handing - DIN left / right

Stand facing the door on the hinge side / pull side. If the hinge or pivot is to your right hand side the door is considered to be DIN right. If the hinge or pivot is to your left hand side the door is considered to be DIN left.

IMPORTANT WARNING:

HIGH INTERNAL PRESSURES, UNDER NO CIRCUMSTANCES ATTEMPT TO DISMANTLE THE CLOSER.

TS 550



TS 550 Designations:-

A - Clamping screws

B - Spindle screw

C - Spindle

D - Cover plate fixing holes

E - Regulating valve
(delayed action only)

F - Regulating valve
(closing speed)

G - Adjustment screw
(hold open angle)

H - Hold open on/off screw

I - Height adjusting screws

J - Clamping claw

K - Clamp claw screw

L - Closing force adjustment

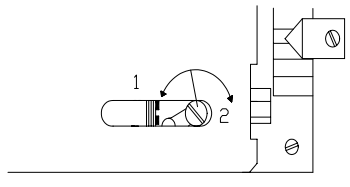
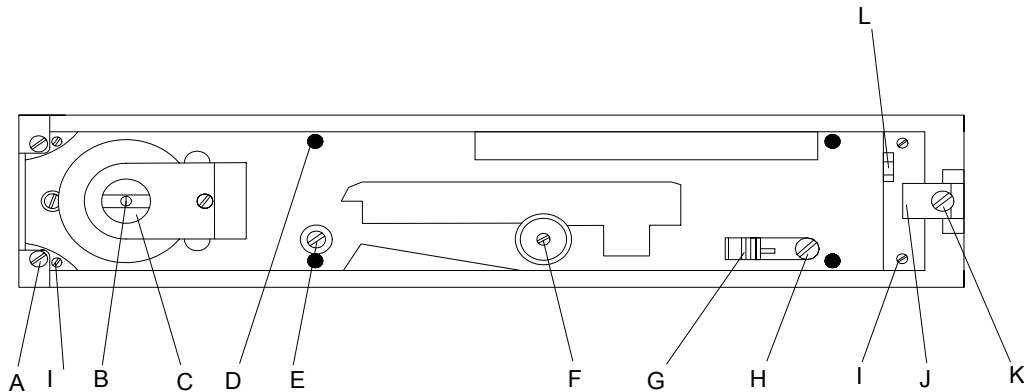

Diagram 2

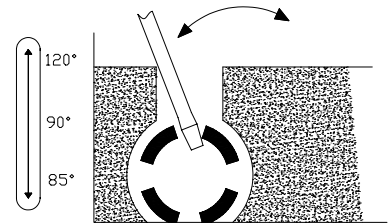

Diagram 3

➤ Recess for cement box depending on type of closer, (see diagram 1).

➤ Align cement box and cast in place with quick drying cement. Top edge of box level with floor. Compensate for inaccuracies in installation by moving the closer within the cement box and with the height adjustment screws, when in position lock in place with the clamp screws. (closer is adjustable by 10mm in each direction)

➤ Cover the closer while any building work is in progress with the reinforcing plate, if installed outside or in an environment where the floor may become wet we recommend sealing the unit with Geze sealing compound.

➤ Selecting/Deselecting hold open:

Rotate hold open screw to either position 1 to disengage the hold open or position 2 to engaged hold open (see diagram 2)

Hold open:

80°-115° single action doors

85°-120° double action doors

The closer is delivered with the hold open unit on (position 2)- hold open angle factory set at approximately 90°

➤ To adjust the hold open angle remove the cover plate, remove seal from slot S (see diagram 3). Open the door to the hold open angle, if the door does not hold open the cause may be one of the following:

Closer not primed, Prime the closer by opening the door to 90°, allowing the door to close half way then push back to 90°, and/or

Hold open angle not set, insert screwdriver into slot of adjusting screw G and rotate by lever action (see diagram 5)

Anticlockwise (screwing out) will decrease the hold open angle.

Clockwise (screwing in) will increase the hold open angle.

➤ The closing force is adjusted by rotating H using a 10mm spanner,

turning H clockwise will increase the closing force, turning H anticlockwise will decrease the closing force. The range of closing force is 2-5 EN. (13-37 Newton Metres).



The closing speed is adjusted by rotating screw F using a flat blade screwdriver. (see diagram 4)

- Rotating anticlockwise will increase the closing speed
- Rotating clockwise will decrease the closing speed.

Diagram 4

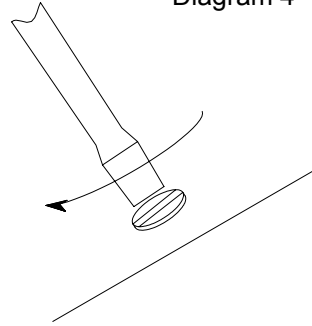

To adjust or replace the toothed spindle:-

- screw off shaft top part with 4mm A/F Allen key (see diagram 3)
- remove clamping screw and insert into new spindle, 3-4 complete turns will be enough. Insert new spindle and clamping screw into closer and tighten holding the spindle in line with toothed shaft. Ensure teeth inter link correctly. (see diagram 5)

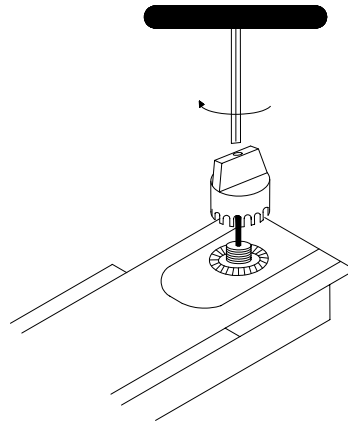
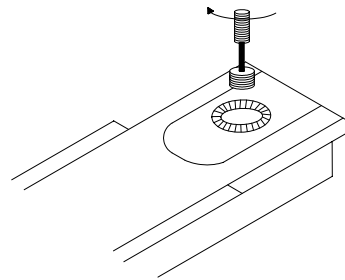

Diagram 5



Fitting the cover plate, for DIN left-hand and DIN right-hand double action door: (see diagram 6)

Reinforcement plate

This is used in heavy traffic areas and fixed between the floor spring and the cover. There are no extra fixings as it uses the same screws and holes as the cover plate.

Diagram 6

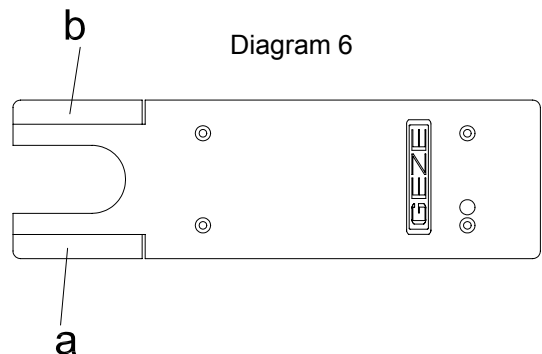

- DIN right-hand A - Break off, using pliers, either
- DIN left-hand B - a or b depending on the required hand